

## Installation

### Safety Warning

When installing a positioner, please ensure to read and follow safety instruction.

- All input and supply pressure to valve, actuator, and other related devices must be turned off.
- Use bypass valve or other equipment to avoid entire system "shut down."
- Make sure there is no remaining pressure in the actuator.

### Tools for Installation

- ① Hexagonal wrench
- ② Screw drivers (+) & (-)
- ③ Spanners for hexagonal-head bolts

### YT-2500L Installation

YT-2500L should be installed on linear motion valve such as globe valve or gate valve using spring return type of diaphragm or piston actuator. Before installation, be sure to check for following installation components.

- ① YT-2500 main body
- ② Feedback lever and lever spring
- ③ Flange nut (bottom side of YT-2500L)
- ④ 4 pcs of hexagon head bolts (M8 x 1.25P)
- ⑤ 4 pcs of M8 plate washer

### Installation Steps

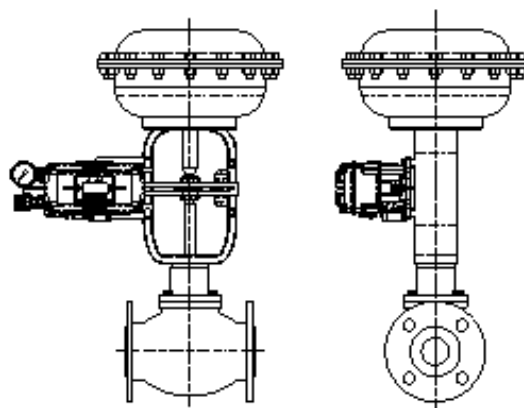

YT-2500L installation example

- 1) Proper bracket must be made in order to attach positioner on the actuator yoke. Please consider following when making a bracket.
  - ① Feedback lever should be leveled at 50% of the valve stroke. (Refer to Step 7)
  - ② Feedback lever connection bar of actuator clamp should be installed at the positioner that the valve stroke and numbers which indicated on the feedback lever must be fitted. (Refer to Step 8)
- 2) Attach YT-2500L to the bracket, which was made in earlier step, by using bolts. <Figure 2> Please refer to backside of the product for size of the bolts. The standard size of bolt is M8 x 1.25P, and other bolt sizes are available. Please contact YTC sales department.

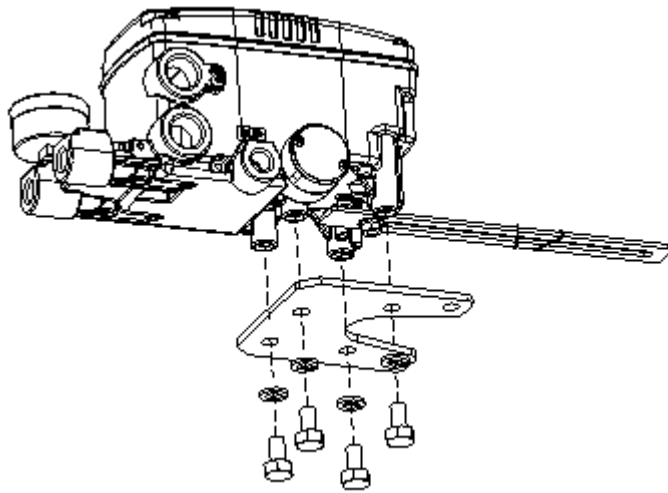

<Figure 2: Installing YT-2500L with bracket>

- 3) Attach YT-2500L (with bracket) to the actuator yoke – DO NOT TIGHTEN COMPLETELY.
- 4) Connect YT-2500L feedback lever to the actuator clamp. The gap on the YT-2500L feedback lever is 6.5mm. The connection bar thickness should be less than 6.3mm.  
<Figure 3>

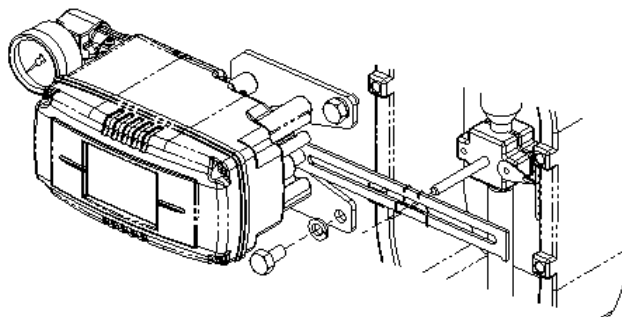

<Figure 3>

- 5) Connect air filter regulator to the actuator temporarily. Set supply pressure of the regulator in order to position the actuator clamp at 50% of valve stroke. <Figure 4>

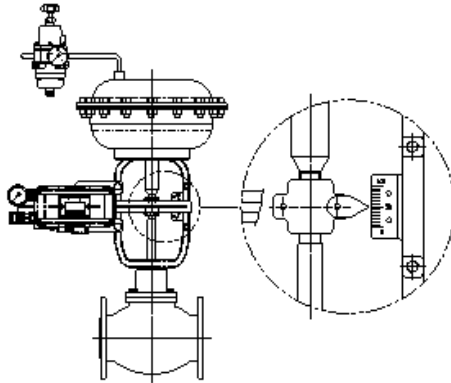

<Figure 4>

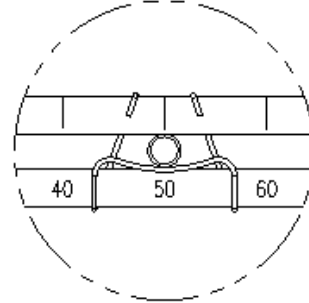

<Figure 5>

- 6) Insert connection bar into the YT-2500L feedback lever. The connection bar should be inserted at the 50% point on the feedback lever, which would help to reduce hysteresis. <Figure 5>
- 7) If connection bar does not point at 50% point, then adjust bracket or feedback link bar position. Failure to position at 50% would lower the linearity of the positioner. <figure 6>

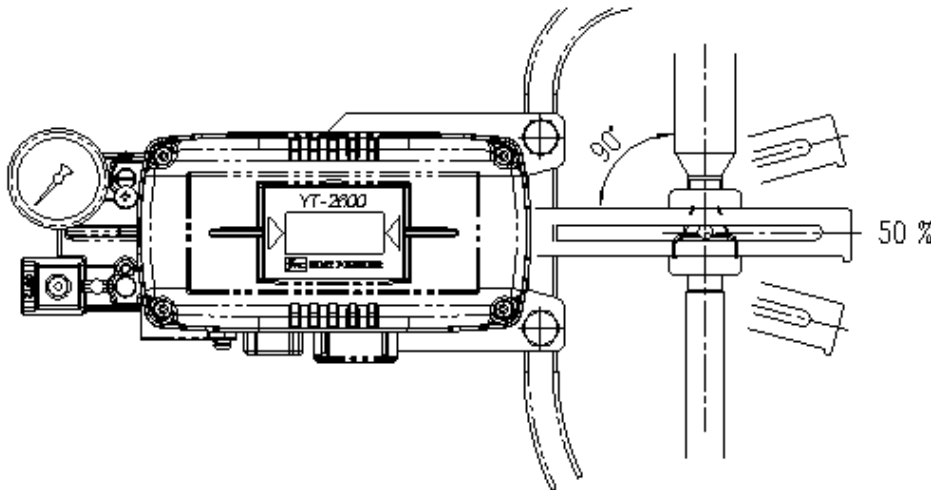

<Figure 6>

- 8) Check valve stroke. The stroke numbers are indicated on the feedback lever. Position connection bar at the number on the feedback lever according to the valve stroke. <Figure 7> To adjust, move the bracket or the connection bar.

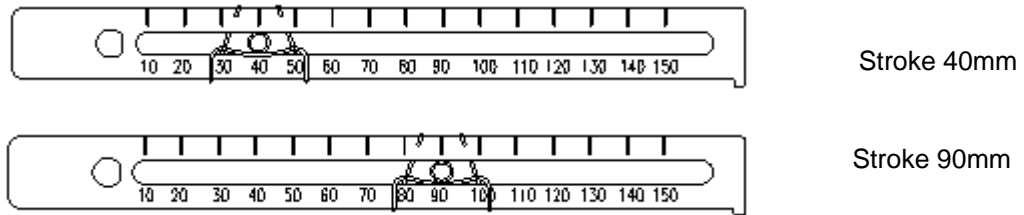

&lt;Figure 7&gt;

**Note**

After installing YT-2500L, operate the valve from 0% to 100% stroke by using air filter regulator on the actuator. Both of 0% and 100%, the feedback lever should not touch the lever stopper, which is located on the backside of YT-2500L. <Figure 8> If the feedback lever touches the lever stopper, YT-2500L should be installed further away from the center of the yoke.

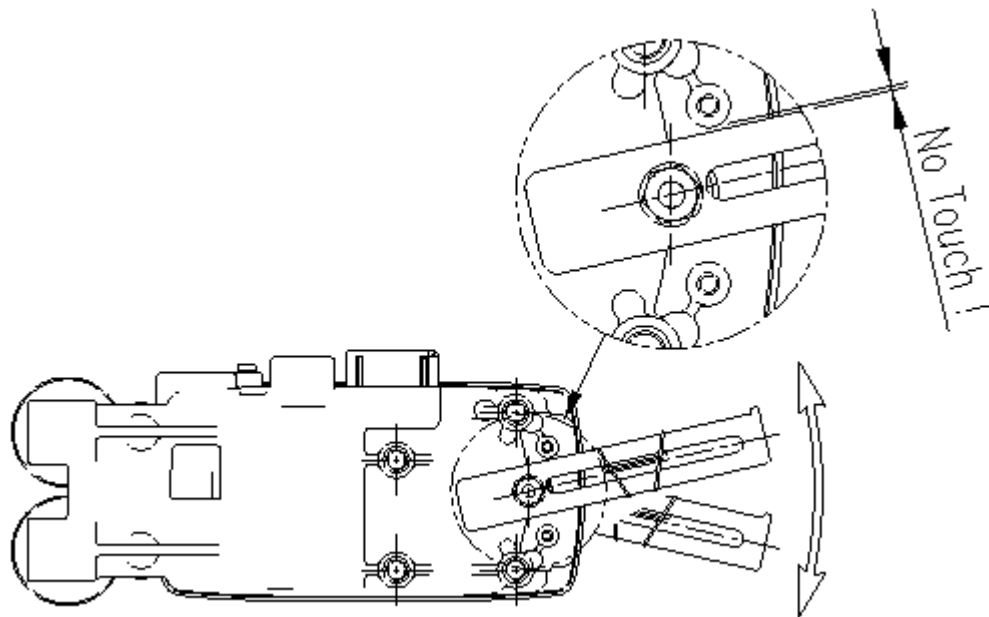

&lt;Figure 8&gt;

- 9) After the proper installation, tighten all of the bolts on the bracket, the feedback lever, and the connection bar.

### YT-2500R Installation

YT-2500R should be used for rotary motion valve, that is ball valve, butterfly valve using rack and pinion, scotch yoke or complex type actuator, which its stem rotates 90 degrees. Before installation, be sure to check for following installation components.

- ① YT-2500R main body
- ② Fork lever and lever spring
- ③ 1 set of bracket
- ④ 4 pcs of hexagon head bolts (M8 x 1.25P)
- ⑤ 4 pcs of M8 plate washer

### YT-2500R Installation Example

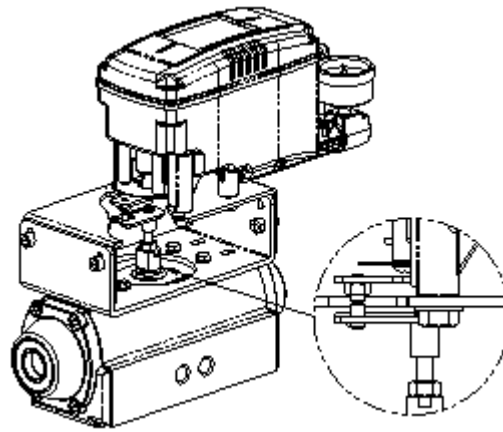

YT-2500R on Fork Lever

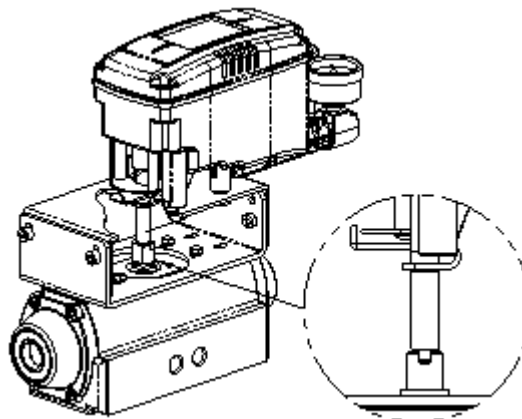

YT-2500R on NAMUR Lever

**Bracket Information**

YT-2500R is supplied with standard bracket. The bracket can be used for Fork lever and NAMUR bracket. Please see <Figure 9, 10, & 11> for more detailed information.

Actuator stem height (H)	Markings of bolt holes			
	A-L	B-L	A-R	B-R
20mm	H : 20	H : 20, 30	H : 20	H : 20, 30
30mm	H : 30	H : 20, 30	H : 30	H : 20, 30
50mm	H : 50	H : 50	H : 50	H : 50

<Figure 9>

- 1) Standard actuator stem height (H) is 20, 30, or 50 mm. After checking “H”, assemble with the bracket as shown in <Figure 9, 10, 11>

Actuator Stem (H)

Actuator

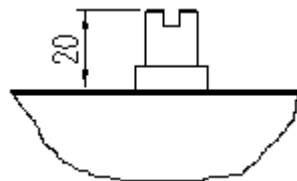

<Figure 10>

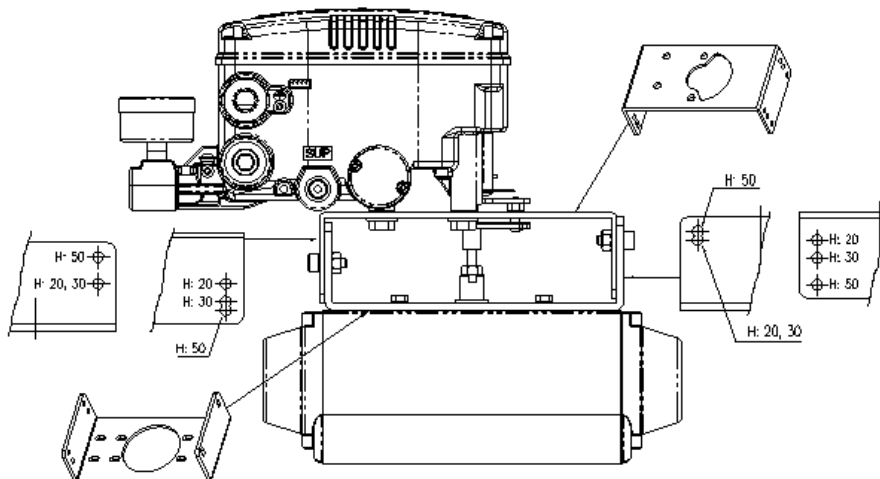

<Figure 11>

\* For example, when "H" is 30mm, A-L should be locked with H:30 hole and B-L in H:20,30, A-R with H:30 and B-R with H:20,30 marking.

- 2) Attach bracketed YT-2500R to the actuator by using hexagon-headed and wrench bolts. Size of the bracket hole is 6mm. When tightening bolts, please use spring washer or similar for firm attachment to the actuator, so YT-2500R will not be affected by vibration or any other impact. The direction of bracket is different by operating condition, but normally, the positioner is installed as shown in <Figure 12.>

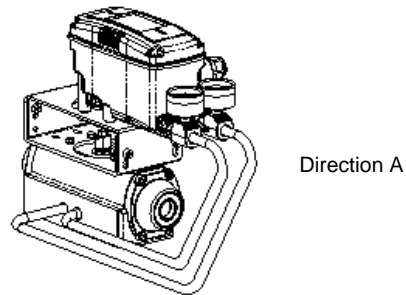

<Figure 12>

- 3) Set rotation position of the actuator stem at zero point, "0%". For a single type of actuator, it is easy to check zero point, because the actuator stem is positioned at zero point when there is no supply pressure. If double acting actuator is used, check actuator stem's rotation direction (clockwise or counter-clockwise) by supplying pressure.
- 4) Install the fork lever as shown in <Figure 13> after setting actuator stem at zero point. Check the direction of the actuator stem – clockwise or counter-clockwise. Installation angle of the fork lever should be 45 degrees based on the linear shaft. For NAMUR shaft, the angle does not matter.

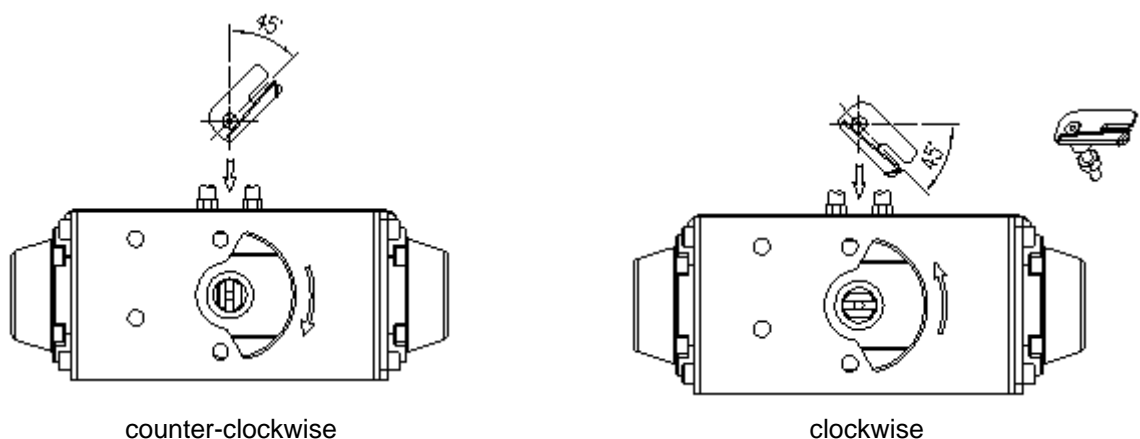

<Figure 13>

- 5) After setting fork lever position, assemble lock nuts which are located on the bottom of the fork lever. Make sure to set the height of upper fork lever between 6-11 mm, which is lower than upper bracket height. <Figure 14>

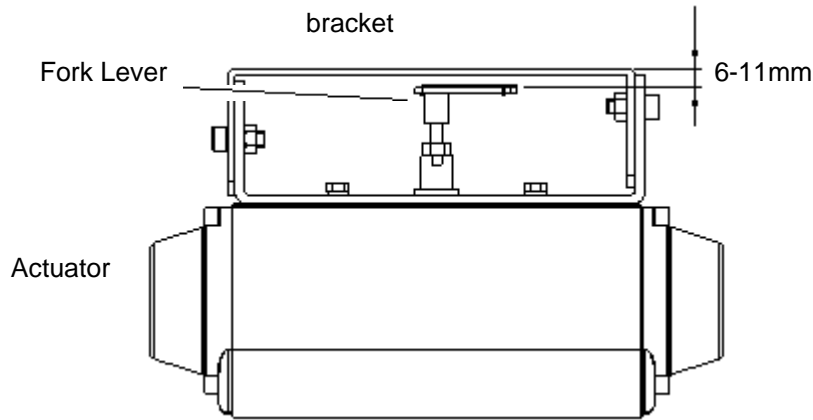

<Figure 14>

- 6) Attach YT-2500R to the bracket. Fix the clamping pin on the main shaft's center of YT-2500R and insert connection bar into the fork lever slot, so it can be locked to the fork lever spring. This sets the alignment of the main shaft of YT-2500R and center of the actuator stem. Bad alignment of the main shaft and the actuator stem lowers YT-2500R's durability, because too much force will be on the main shaft of YT-2500R. <Figure 15>

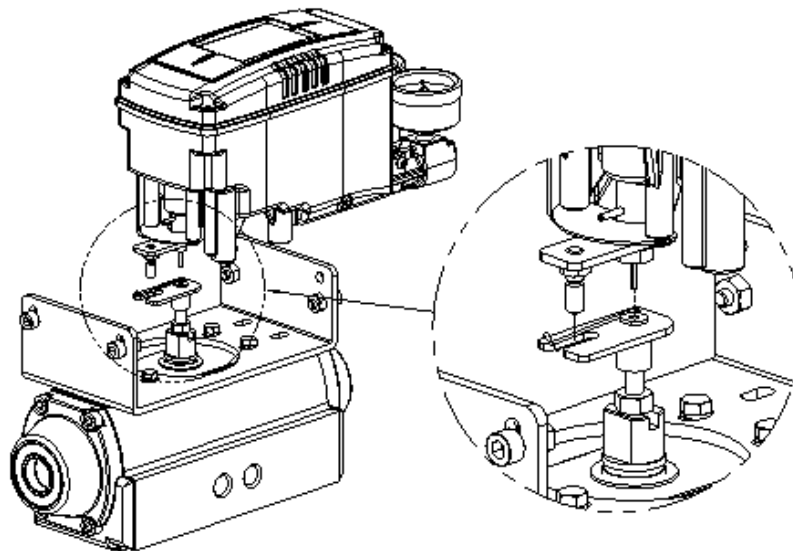

<Figure 15>



7) Tighten YT-2500R base and the bracket with hexagon-headed bolts and plate washer. It is recommended to tighten four bolts after checking YT-2500R's position. <Figure 16>

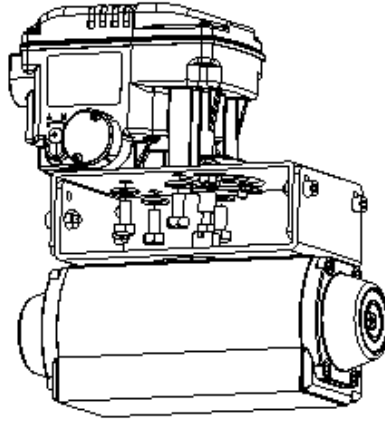

<Figure 16>