

1 2 3 4 5 6 7

REV.NO.	REVISION DESCRIPTION	DRAWN / DATE	REVIEWED / DATE	APPROVED / DATE
△1	First issued	KCH/20120117	JCS/20120117	LYH/20120117
	Omission in the middle			
△2	Drawing arrangement	KBJ/20160429	KCH/20160429	JCS/20160429
△3	Company name changed ...	KSH/20190925	KCH/20190925	KTJ/20190925

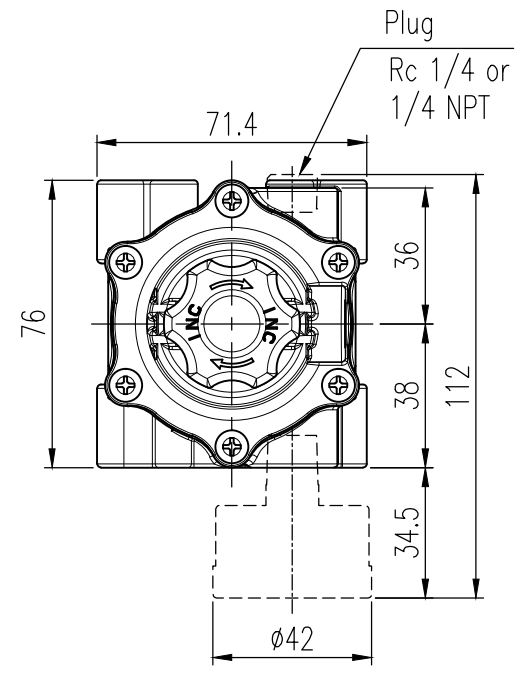

Characteristic

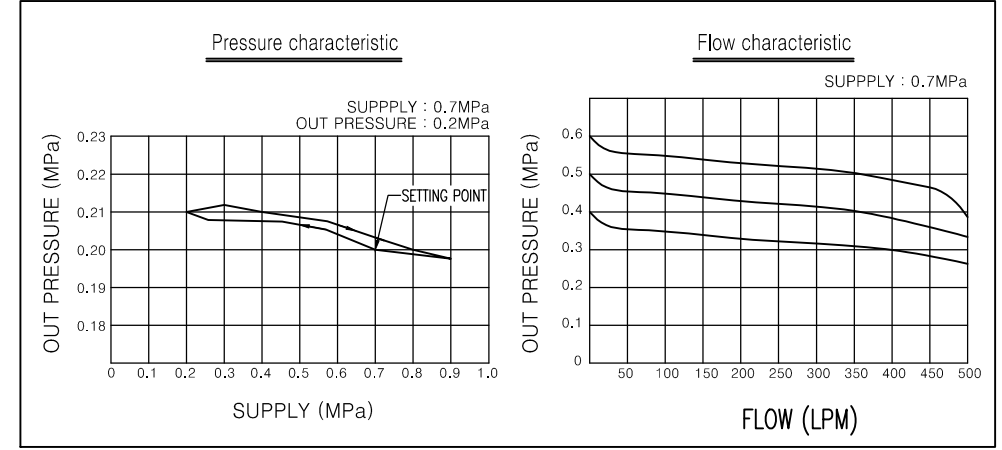

Specification

Item	Description
Max. supply pressure	1.7 MPa (17 bar)
Max. out pressure	<input type="checkbox"/> A : 0 ~ 0.42 MPa (4.2 bar)
	<input type="checkbox"/> B : 0 ~ 0.84 MPa (8.4 bar)
Air connection, Gauge connection	<input type="checkbox"/> Rc 1/4
	<input type="checkbox"/> 1/4 NPT
Ambient temperature	Standard <input type="checkbox"/> -20 ~ 70 °C (-4 ~ 158 °F)
	High <input type="checkbox"/> -20 ~ 120 °C (-4 ~ 248 °F)
	Low <input type="checkbox"/> -40 ~ 70 °C (-40 ~ 158 °F)
	Arctic <input type="checkbox"/> -50 ~ 70 °C (-58 ~ 158 °F)
Min. filtering size	5 Micron
Housing material	Aluminum
Weight	0.62 kg (1.4 lb)

No.	Part name	Material	Q'ty	Remark
1	Adjust bolt	STS304+PC	1	
2	Nut(M8x1.0P)	STS304	1	
3	Base cover	ALDC12	1	
4	Diaphragm ass'y	NBR	1	Standard
		Silicone		Low/High/Arctic Temp.
5	Base body	ALDC12	1	
6	Filter case	ALDC12	1	
7	Drain plug	STS304	1	

Pressure gauge

No.	Max. out pressure	Part name	Specification	Material	Q'ty	
8		<input type="checkbox"/> None			STS304	1
		A type	<input type="checkbox"/> Agage-05	Rc 1/4, 0.4 MPa		
			<input type="checkbox"/> Agage-08	1/4 NPT, 0.4 MPa		
		B type	<input type="checkbox"/> Agage-07	Rc 1/4, 1.0 MPa		
<input type="checkbox"/> Agege-10	1/4 NPT, 1.0 MPa					

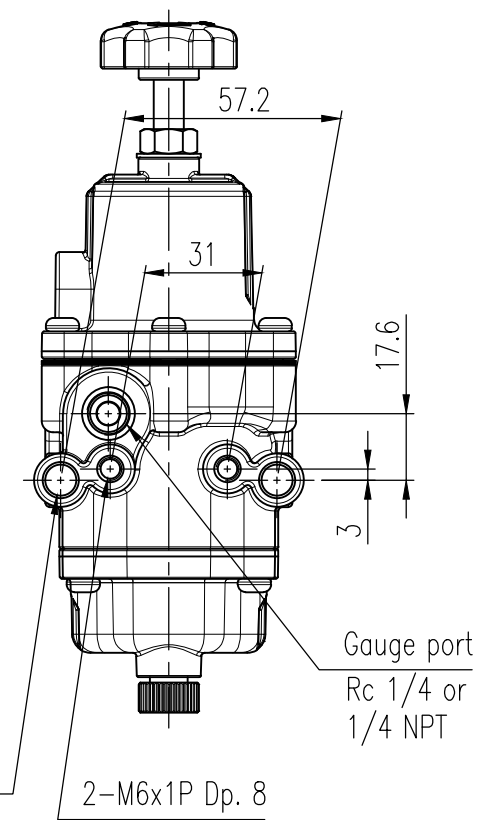
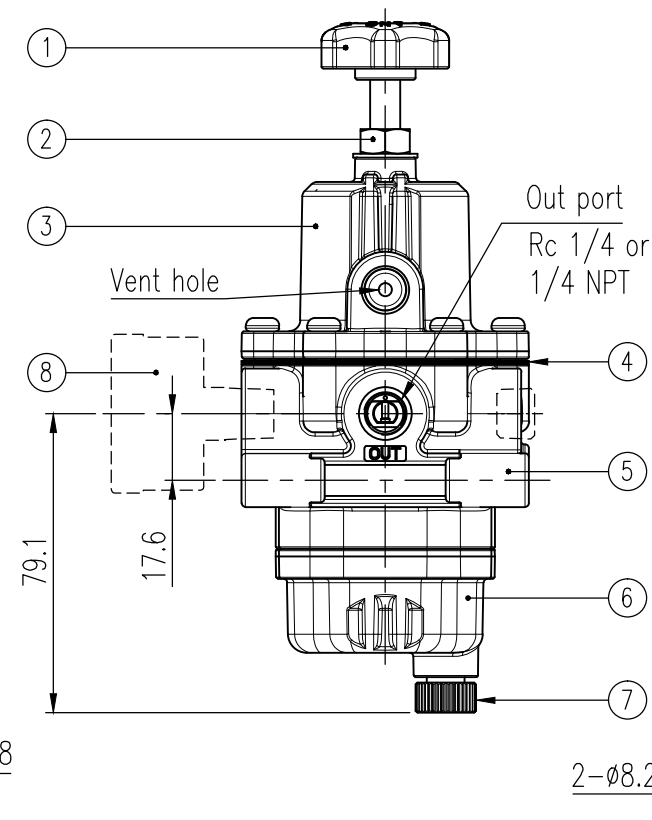
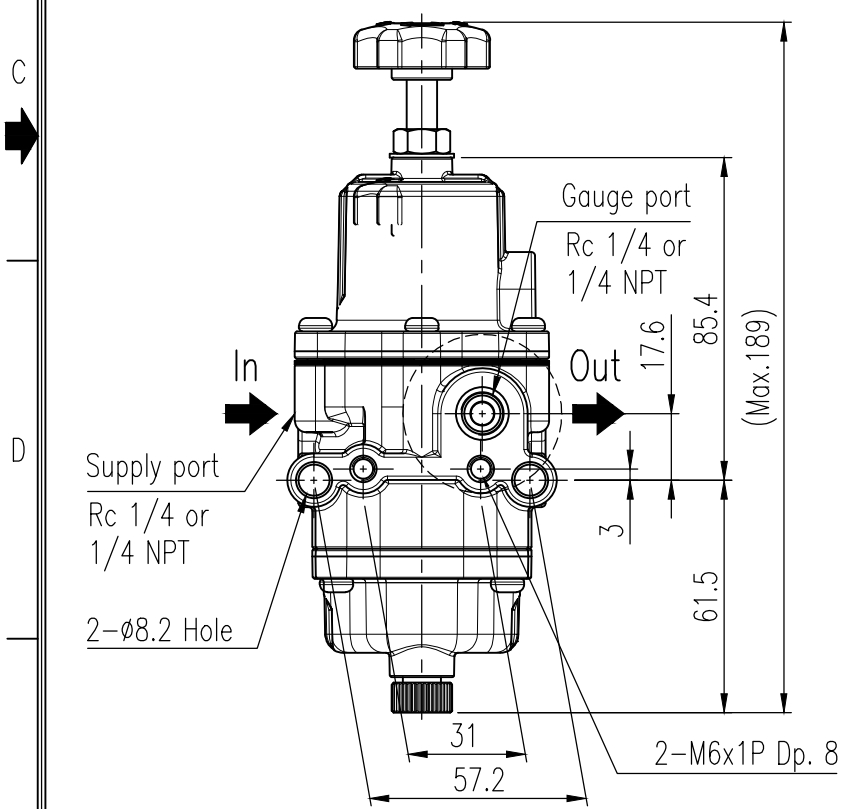

NOTE

1. Condensation capacity of filter case : 32cm³

SURFACE TEXTURE		PRODUCT NAME		Rotork YTC Limited GMP0-SI, KOREA	
FINISH TREATMENT		Air filter regulator			
MATERIAL		MODEL		TITLE	
OTHERWISE NOTE		YTC-200		Standard drawing	
GENERAL TOLERANCE		PROJECTION		DRAWING NO.	
		SCALE 1/2		YTC-200-01	
		QUANTITY		REV.	
		SHEET No. 1/1		5	