

REV.NO.	REVISION DESCRIPTION	DRAWN / DATE	REVIEWED / DATE	APPROVED / DATE
△1	First Issued	MDK/20060325	JCS/20060325	LYH/20060325
	Omission in the middle			
△2	Drawing arrangement	LJS/20110425	JCS/20110425	LYH/20110425
△3	Company name changed	KCH/20191104	JCS/20191104	KTJ/20191104

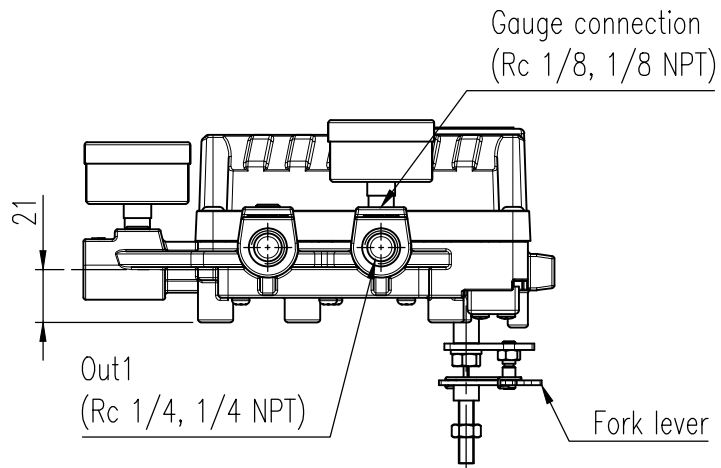
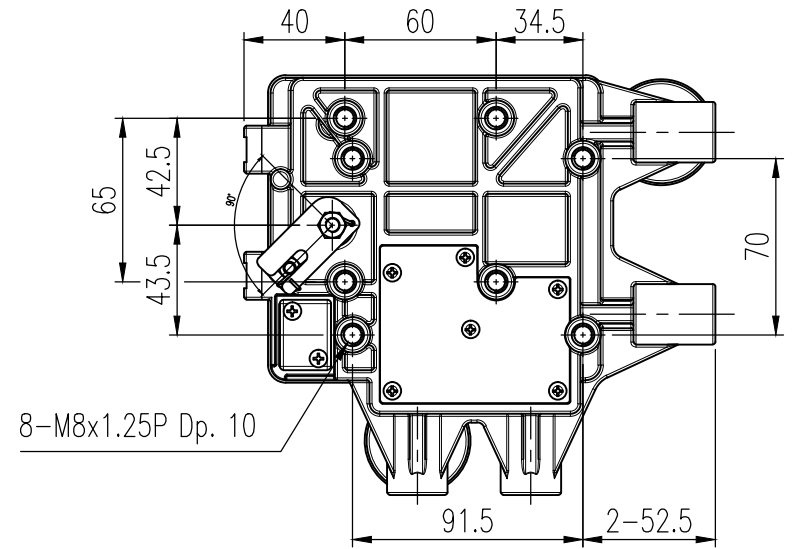
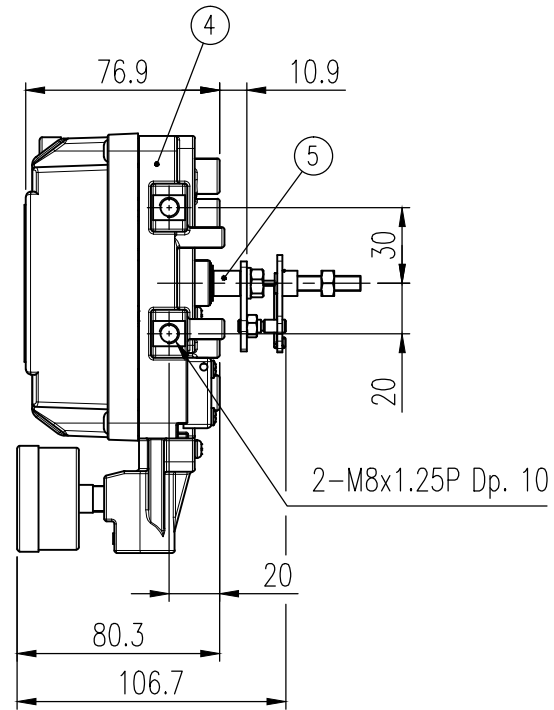
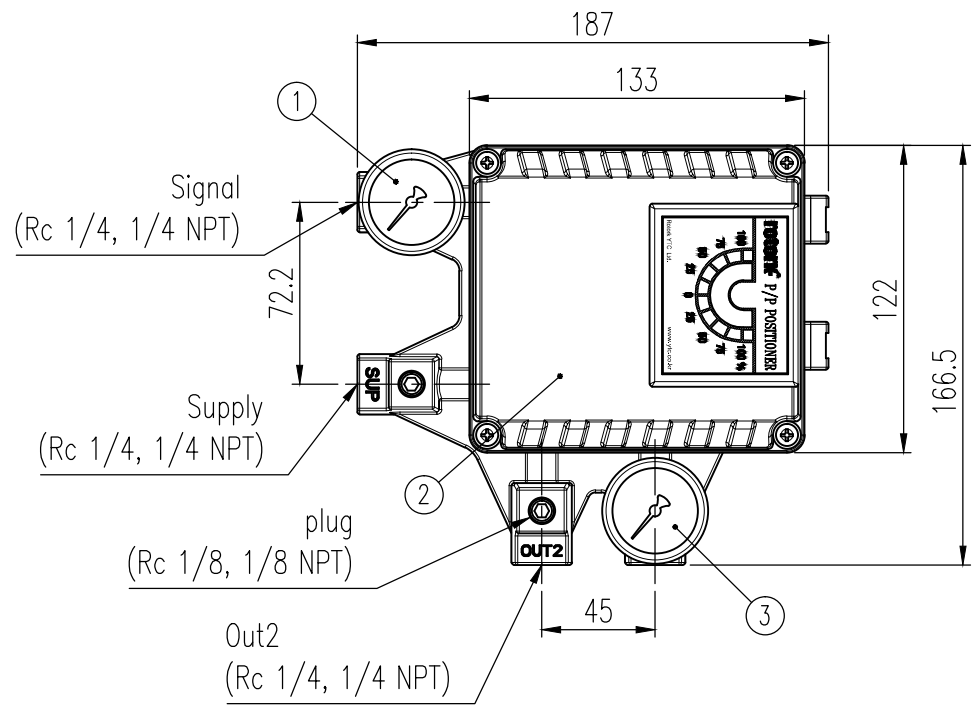

Specification

Applicable Fluid	Air	
Acting Type	<input type="checkbox"/> Single	<input type="checkbox"/> Double
Input Signal	0.02 ~ 0.1MPa (0.2 ~ 1bar)	
Supply Pressure	0.14 ~ 0.7MPa (1.4 ~ 7bar)	
Stroke	55 ~ 100"	
Air Connection, Gauge Connection	<input type="checkbox"/> Rc 1/4, Rc 1/8	<input type="checkbox"/> 1/4 NPT, 1/8 NPT
Operating Temp.	Standard	<input type="checkbox"/> -20°C ~ 70°C (-4°F ~ 158°F)
	High	<input type="checkbox"/> -20°C ~ 120°C (-4°F ~ 248°F)
	Low	<input type="checkbox"/> -40°C ~ 70°C (-40°F ~ 158°F)
Pressure Gauge	Signal	0.2MPa
	Output 1	<input type="checkbox"/> 0.8MPa : Standard <input type="checkbox"/> 0.4MPa : Option

Linearity	±2.0% F.S.	
Hysteresis	±1.0% F.S.	
Sensitivity	±0.5% F.S.	
Repeatability	±0.5% F.S.	
Flow Capacity	> 80 LPM (Sup.=0.14MPa, 1.4bar)	
Air Consumption	< 2.5 LPM (Sup.=0.14MPa, 1.4bar)	
Ingress Protection	IP66	
Weight	1.7kg (3.1 lb)	
Feedback connection type	<input type="checkbox"/> M6x34L	<input type="checkbox"/> M6x63L
	<input type="checkbox"/> M8x34L	<input type="checkbox"/> M8x63L
Housing Material	Aluminum	
	<input type="checkbox"/> NAMUR	

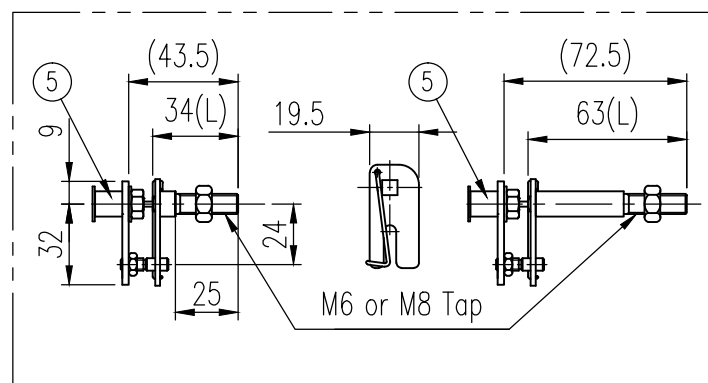

Fork lever type

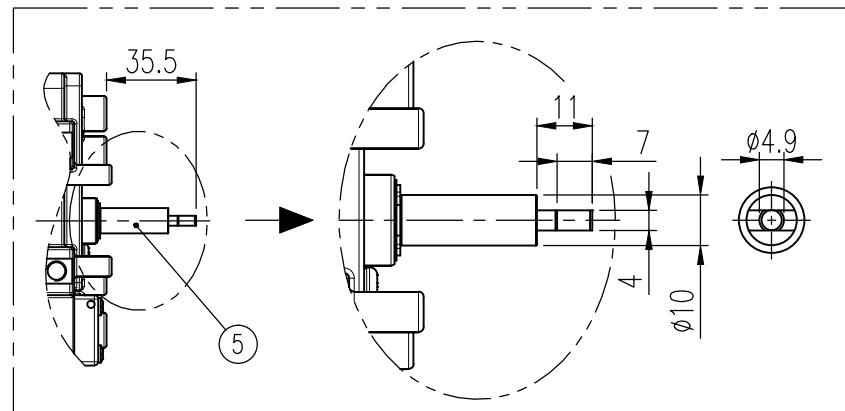

NAMUR shaft type

No.	Part name	Material	Q'ty	Remark
1	Pressure gauge	STS304	1	Signal, 0.2MPa
2	Base cover	ALDC12	1	
3	Pressure gauge	STS304	1	Out1, 0.8 MPa
4	Base body	ALDC12	1	
5	Main shaft	STS303	1	

SURFACE TEXTURE	PRODUCT NAME		PROJECT NAME	
FINISH TREATMENT	P/P Positioner			
MATERIAL	MODEL		TITLE	
OTHERWISE NOTE	PROJECTION		Rotork® Rotork YTC Limited	
GENERAL TOLERANCE	SCALE		GIMPO-SI, KOREA	
	3rd		Rotary Standard	
	1		Positioner drawing	
	1		DRAWING NO.	
	1 / 1		YT-1200R-01	
			REV.	
			6	